

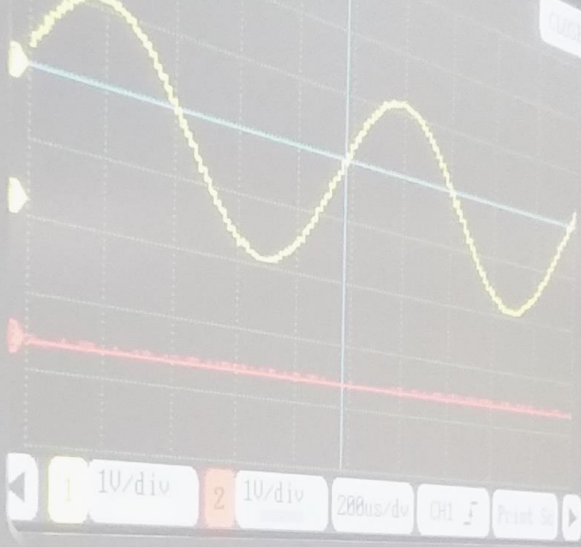

μCore
Electronics

Vpp: 3.04V Urms: 1.74V Umean: 1.44V
ton: 422us toff: 578us freq: 1001 Hz



UCE-DSO290 DIGITAL OSCILLOSCOPE

USER MANUAL

FATİH GENÇ
UCORE ELECTRONICS
www.ucore-electronics.com

Contents

1. Introduction.....	2
2. Turning on or turning off.....	3
3. Oscilloscope Mode.....	3
3.1. Display Description.....	4
3.2. Trigger Setting.....	6
3.3. Channel Setting.....	7
3.4. Horizontal Sensitivity Setting.....	8
3.5. Cursor Function.....	9
3.6. Auto Measurement.....	9
3.7. Operating Mode.....	10
3.8. XY Operating Mode.....	11
3.9. Mathematics Function.....	12
3.10. Data Logging.....	14
4. Signal Generator.....	14
5. Color Setting.....	15
6. USB Disk.....	16
7. File Browse.....	17
8. Screen Calibration.....	18
9. ADC Calibration.....	19

1. Introduction

UCE-DSO290 is designed for common electronic engineering tasks. It is two-channel, high speed oscilloscope. It contains a 32bit ARM Cortex- M4 Series processor with integrated high-speed FIFOs and ADCs.

Internal 8MB USB disk could be used to store waveform and upgrade firmware.

Features:

- Display: 4.3 inch 480 × 272 pixel color LCD
- Personalization: customization of display colors
- Two channel inputs, One channel signal output
- XY Mode
- Analog Band width: 20MHz
- Maximum sampling rate: 112.5Msps 8-bit
- Sampling depth: 16kB
- Input impedance: 1MΩ
- Vertical sensitivity: 10mV/div - 10V/div
- Horizontal sensitivity: 50ns/div - 5s/div
- Max input voltage: ±5V (X1 Probe), ±50V (X10 Probe)
- Coupling: AC/DC
- Supply voltage: 5V (mini USB)
- Trig modes: Run, single, Hold functions
- Trigger functions: rising / falling edge, Triggering Cursor
- Auto Measurement: frequency, ton time, toff time, period time, peak-to-peak voltage, mean voltage, RMS voltage
- Test signal: 1KHz %50 duty-cycle square wave, 2.0Vpp
- Cursor: differential measurement for time and voltage
- FFT analyze: 1024 points FFT analyze
- Math Functions: CH1+CH2, CH1-CH2, CH2-CH1, CH1*CH2, CH1/CH2, CH2/CH1, CH1 FFT, CH2 FFT.
- Signal generator: sinus, sinC, square, triangle, sawtooth, arbitrary. (0 - 4.0V, 1Hz - 50kHz)
- Storage: internal 8MB USB disk for storing waveform image and firmware upgrade (bootloader)
- Export ADC data buffer to a Text file.
- Menu language: English
- Weight: 295gr.
- Dimensions: 169x83x31mm
- Power Consumption: 2.5W

Package List:

- 1 pc UCE-DSO290 4.3" TFT Digital Oscilloscope
- 2 pcs X1, X10 Probe
- 1 pc touch pen
- 1 pc USB cable

2. Turning on or turning off

To turn on the device, plug the USB cable into any USB socket whose output voltage is 5V. Energy sources such as computer, adapter and external power bank may be used as voltage source.

To turn off the device, disconnecting power supply will be sufficient.

Attention: Before turning off the device, ensure that the measurement probes are plugged out from the test point.

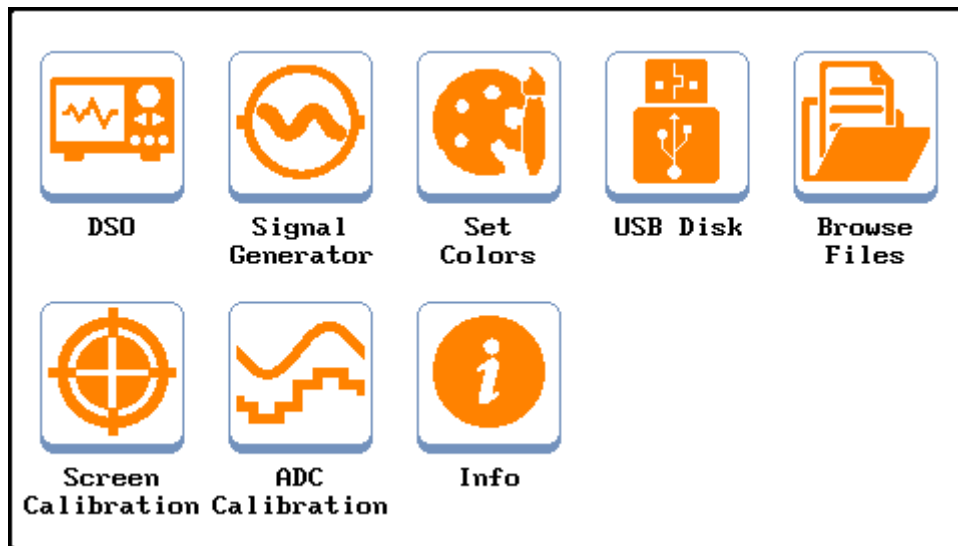

Figure 1. Main Menu image

3. Oscilloscope Mode

For accessing to oscilloscope mode, 'DSO' icon in the 'Main Menu' should be selected. The view of oscilloscope mode is seen in the Figure 2.

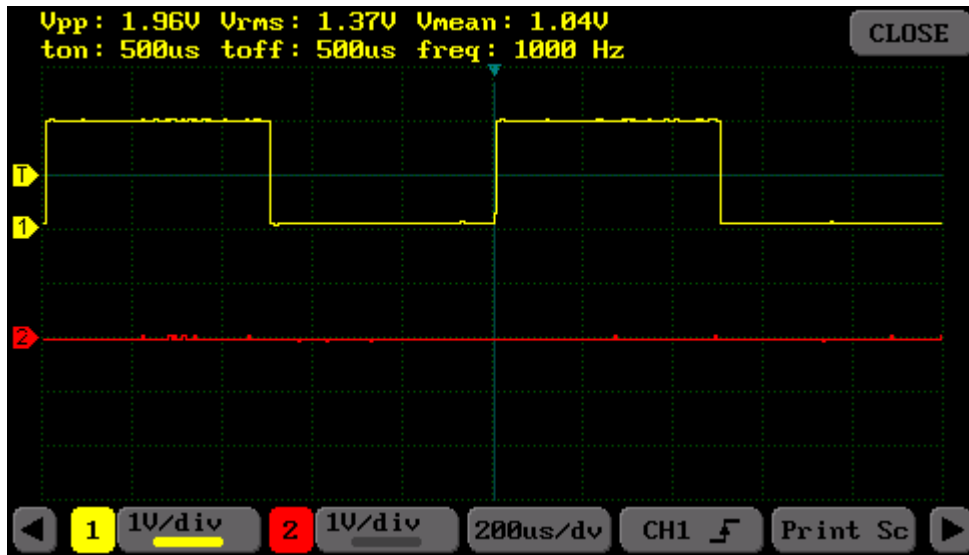

Figure 2. Oscilloscope Mode overview

3.1. Display Description

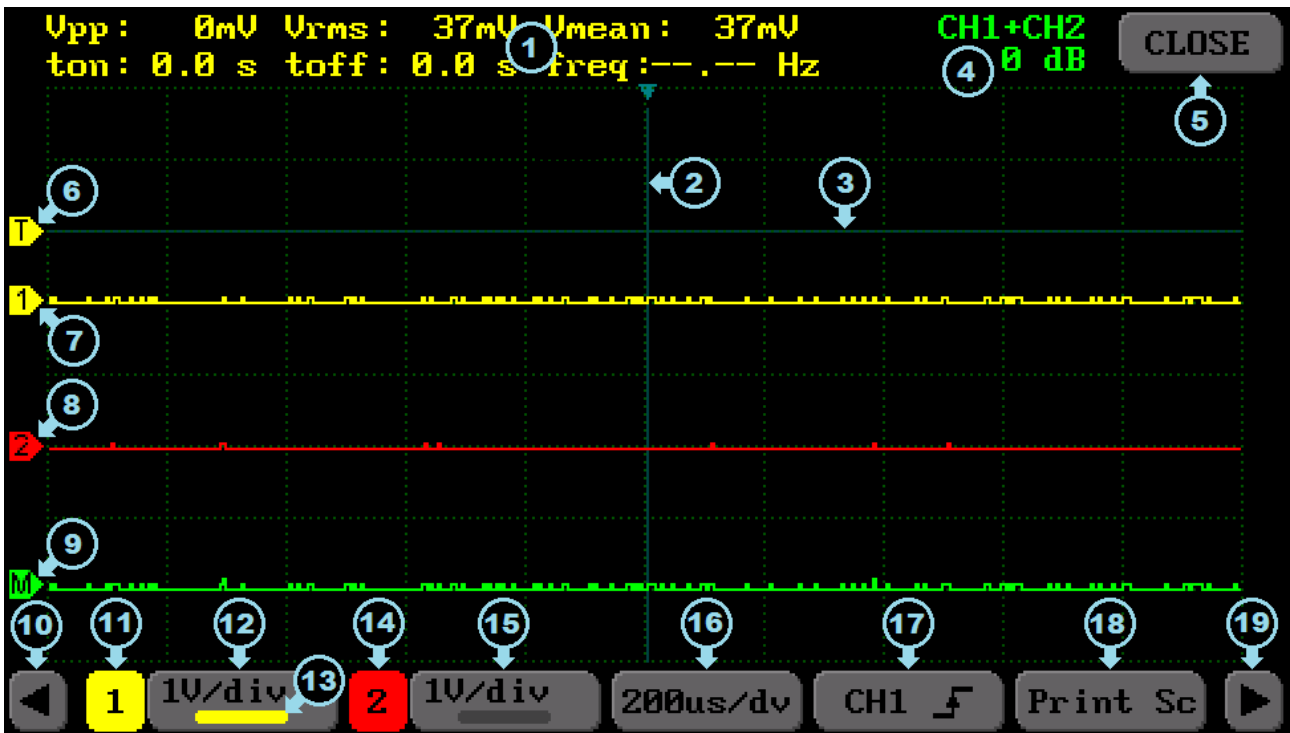

Figure 3a. Oscilloscope mode – Menu1

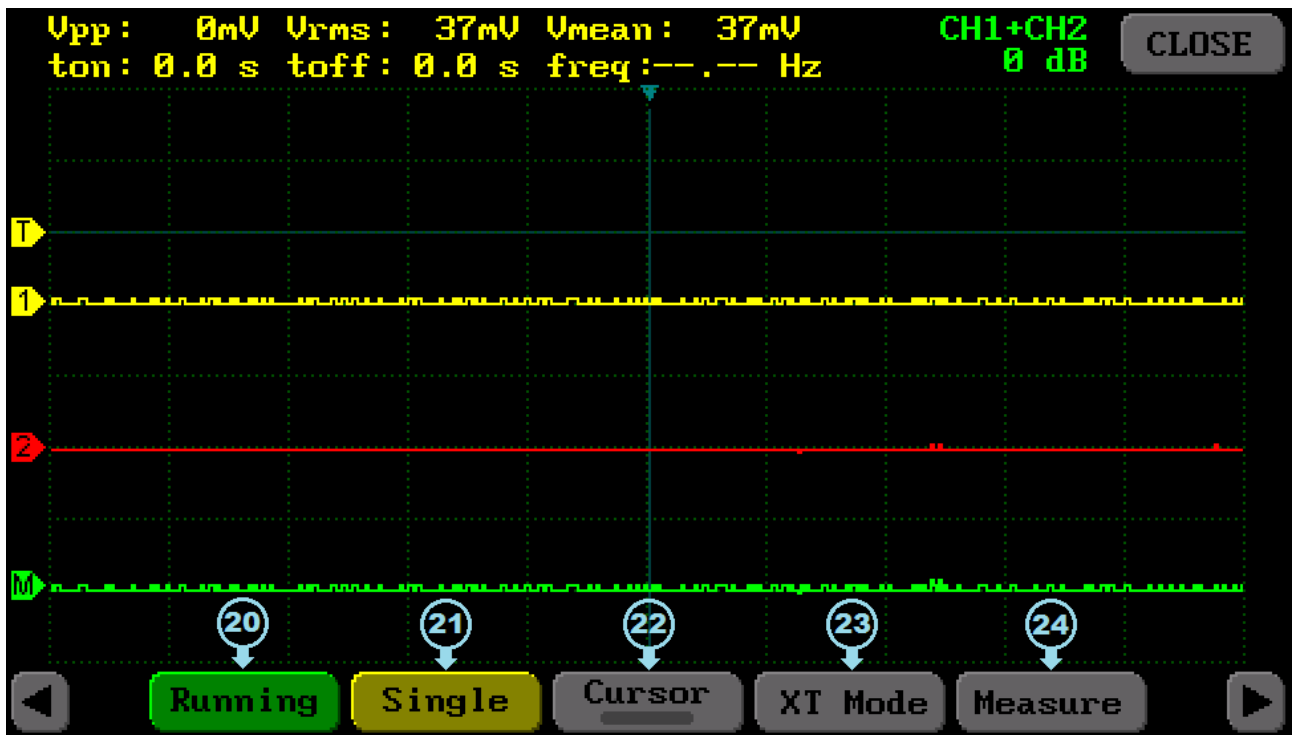

Figure 4b. Oscilloscope mode – Menu2

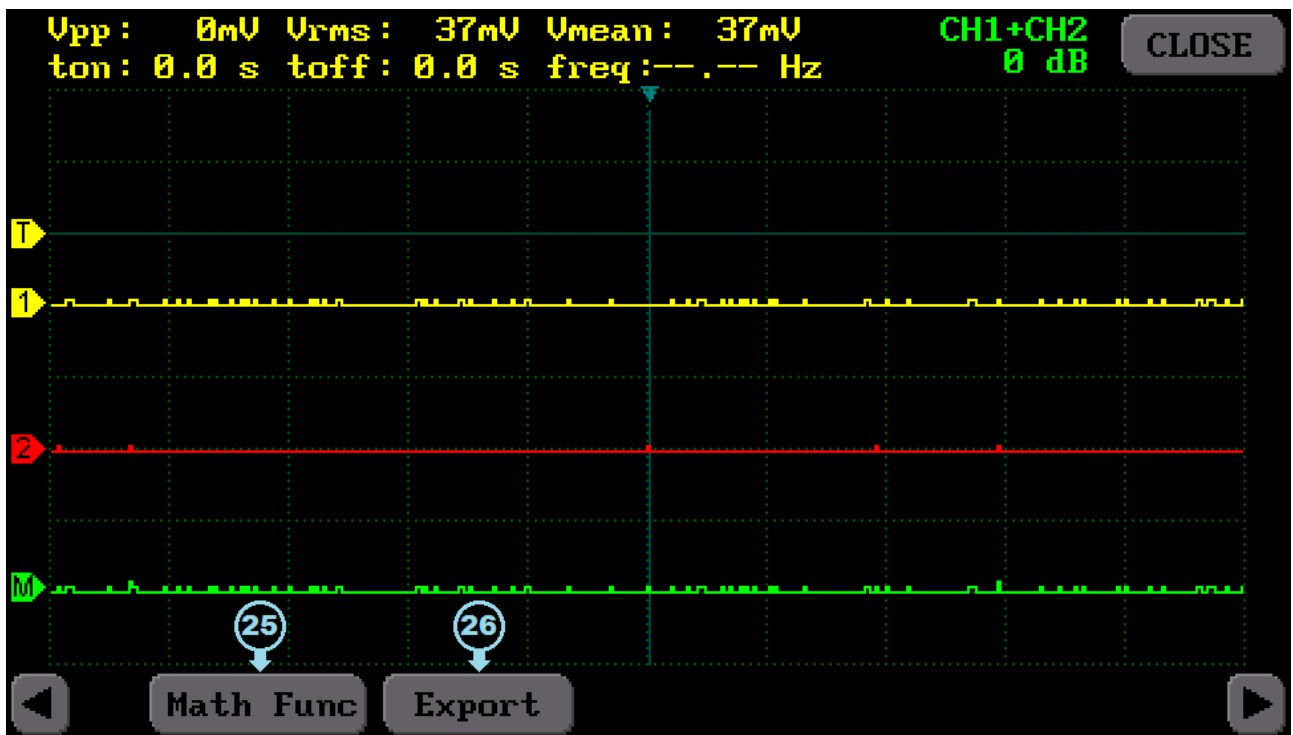







Figure 5c. Oscilloscope mode – Menu3

- 1) The field to show measurements regarding the waveform
- 2) Indicates the horizontal trigger level
- 3) Indicates the vertical trigger level
- 4) Math function data
- 5) Exit from the oscilloscope mode
- 6) The level of vertical triggering, and which channel it stems from by its color
- 7) The ground level of Channel 1
- 8) The ground level of Channel 2
- 9) The ground level of Math Channel
- 10) Provides transition to the previous menu
- 11) The selection button for Channel 1
- 12) The setting button for Channel 1; vertical sensitivity, activation, coupling
- 13) The selection indicator for Channel 1
- 14) The selection button for Channel 2
- 15) The setting button for Channel 2; vertical sensitivity, activation, coupling
- 16) Horizontal sensitivity: Selecting sampling rate. (Time/div)
- 17) Trigger setting
- 18) Provides bmp formatted screen capture
- 19) Provides transition to the next menu
- 20) Automatically trigger or hold
- 21) Single triggering
- 22) Cursor is the menu where the observed signal is measured in terms of time and voltage
- 23) Enables oscilloscope to run as XY or XT option
- 24) Measure: Enables the requested measurement values that shown at (1) to select as Time and/or Voltage
- 25) Math menu
- 26) Enables the data regarding to waveform to be recorded text formatted

3.2. Trigger Setting

To keep the observed signal constant on the display, the trigger source must be selected for that channel. Otherwise, it will be difficult to observe because the signal will be very moving on the display. To choose the trigger source, trigger menu should be opened by pressing the button shown as 17 in the Figure 3a. Then, trigger channel and trigger edge should be selected from the menu seen in the Figure 4.

Table 1. Trigger Modes	
CH1 	Channel 1, rising edge
CH1 	Channel 1, falling edge
CH2 	Channel 2, rising edge
CH2 	Channel 2, falling edge
EXT 	External Trig, rising edge
EXT 	External Trig, falling edge

Info: While making a selection in menus, it is a must to hold down by the touch-pen in the menu area and the requested choice could be made by sliding menu area up and down. To exit from the current menu, press to the menu button again.

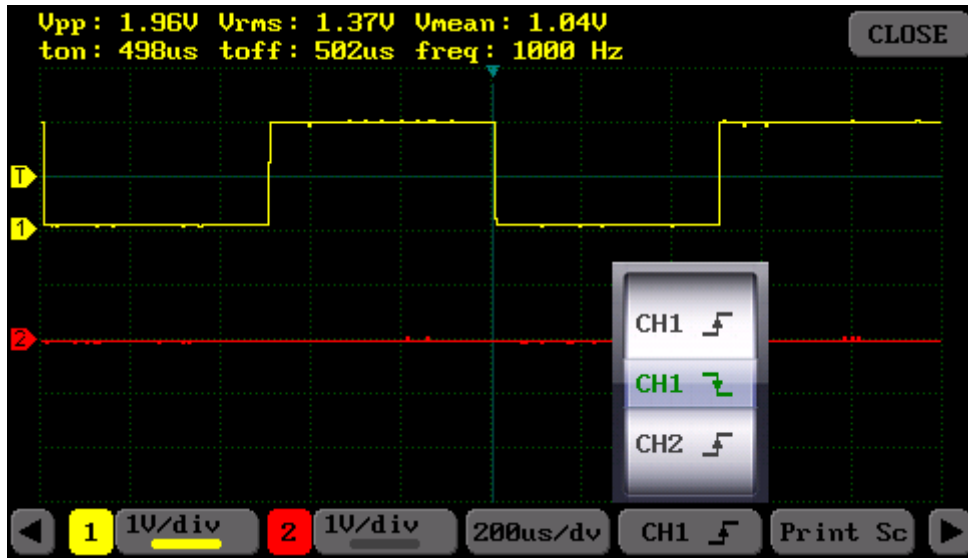

Figure 4. Trigger Menu

After the channel source selection, also it might be needed to choose the trigger level, too. Vertical trigger level (3) must place at somewhere between the signal's maximum and minimum level in order to trigger the signal properly. To set trigger level, firstly, let it activate by holding down with pen to the point where vertical (3) and horizontal (2) trigger levels intersect. Right after the activation, trigger level color shows highlight. Then, the requested level can be adjusted by sweeping the junction point. In case of release the touching on the screen, the triggering level colors fade and lock onto the point.

If the trigger will be made via external signal, firstly, the trigger should be selected from menu as an external channel (Table 1). Henceforth, signal generator output (SG-OUT) is used as an external triggering input. The triggering signal to SG-OUT is applied as square wave. Whereas the voltage between 2V - 5 V, remains at the level of logic-1; the voltage ratings under 0.8V, remains at the level of logic-0. In this kind of trigger, the vertical trigger level remains stable in the middle of the screen owing to the fact that there is no demand on vertical position (3) calibration. The external triggering signal must place between 0V - 5V.

Critical Note: While SG-OUT is used as signal generation, signalization must not be practiced for external trigger. Otherwise, overlap probability between two signals would be inevitable. Firstly, it is a must to select EXT channel from the trigger menu and then signal can be applied.

3.3. Channel Setting

On the purpose of observing the signals clearly on the screen, there may be needed to adjust for every single channel. To adjust the Channel-1, the button numbered (12); to adjust the Channel-2, the button numbered (15) should be selected (Figure 3a). The Channel-1's setting menu is seen in the Figure 5. It consists of two parts: In the menu's left side, vertical sensitivity can be arranged a value ranging from 10mV/div to 10V/div. In the right side of the menu, coupling option can be adjusted as AC or DC. OFF position should be selected to avoid appearing signal on the screen. In a similar way, the settings can be made via the menu numbered (15) for the Channel-2.

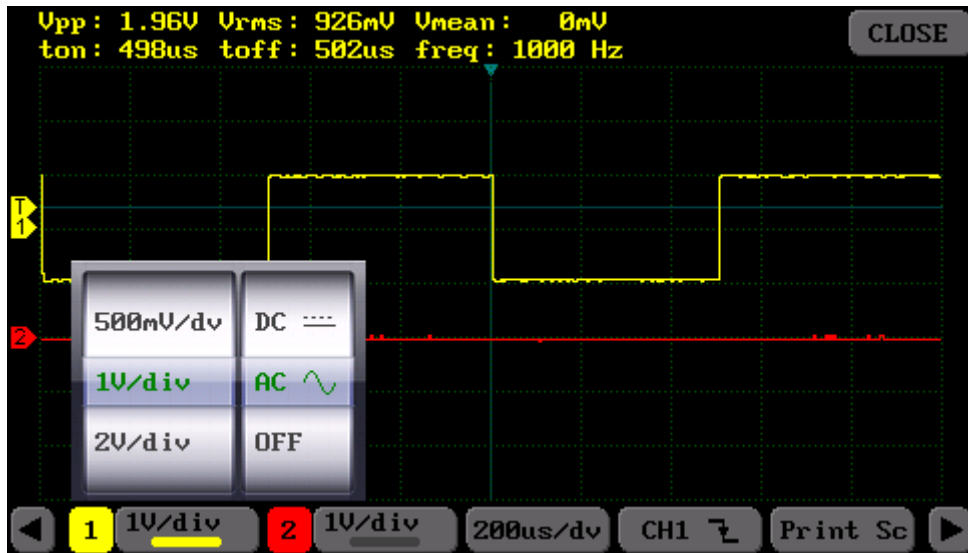

Figure 5. Setting menu for Channel 1

The buttons on the left side of channel setting buttons (11 and 14), provides channel selecting. The required signal via channel tuning can be resituated by sweeping upright on the screen. The selected channel's info is seen in (13) (the selection in the Figure 3a is for Channel-1).

3.4. Horizontal Sensitivity Setting

The horizontal sensitivity setting is what matches up to time setting. Adjusting this should be done smoothly to observe variety of signals in different frequency levels. For the signals that have unrecognized frequency, the horizontal sensitivity should be increased from the minimum level until the signal turns into observable state. The vertical sensitivity may be different for the both channels; however, the horizontal sensitivity corresponding to time is always same.

The horizontal sensitivity can be arranged ranging from 50 ns/div to 5s/div value. As it seen in the Figure 3a, this tuning can be performed from the menu numbered (16).

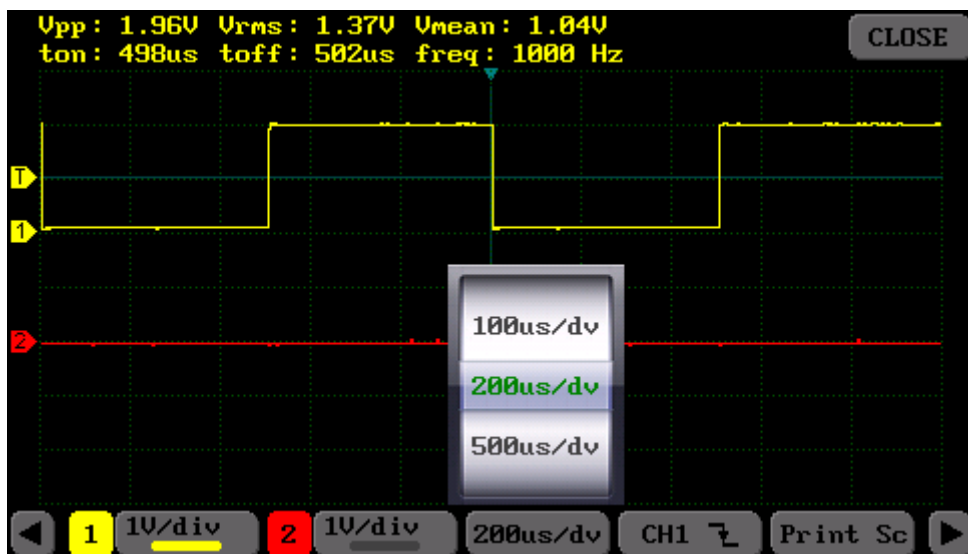

Figure 6. Horizontal sensitivity setting

3.5. Cursor Function

To perform measurement on the observed signal, 'Cursor' menu is used. 'Cursor' menu could be activated by selecting the button which is seen as (22) in the Figure 3b (Menu 2). To switch to Menu 2, the buttons providing switching among the menus are used (in the Figure 3a, (10) and (19) buttons).

There are 4 cursors total which consists of 2 pcs (t1 and t2) for measuring time, 2 pcs (V1 and V2) for voltage. To changeover the cursors, sweep them by holding down with touch-pen. In case the cursor is activated, it gets highlight. The measured values are shown in the second line of the area numbered (1) as time (delta T), voltage (delta V) and the frequency depending on time.

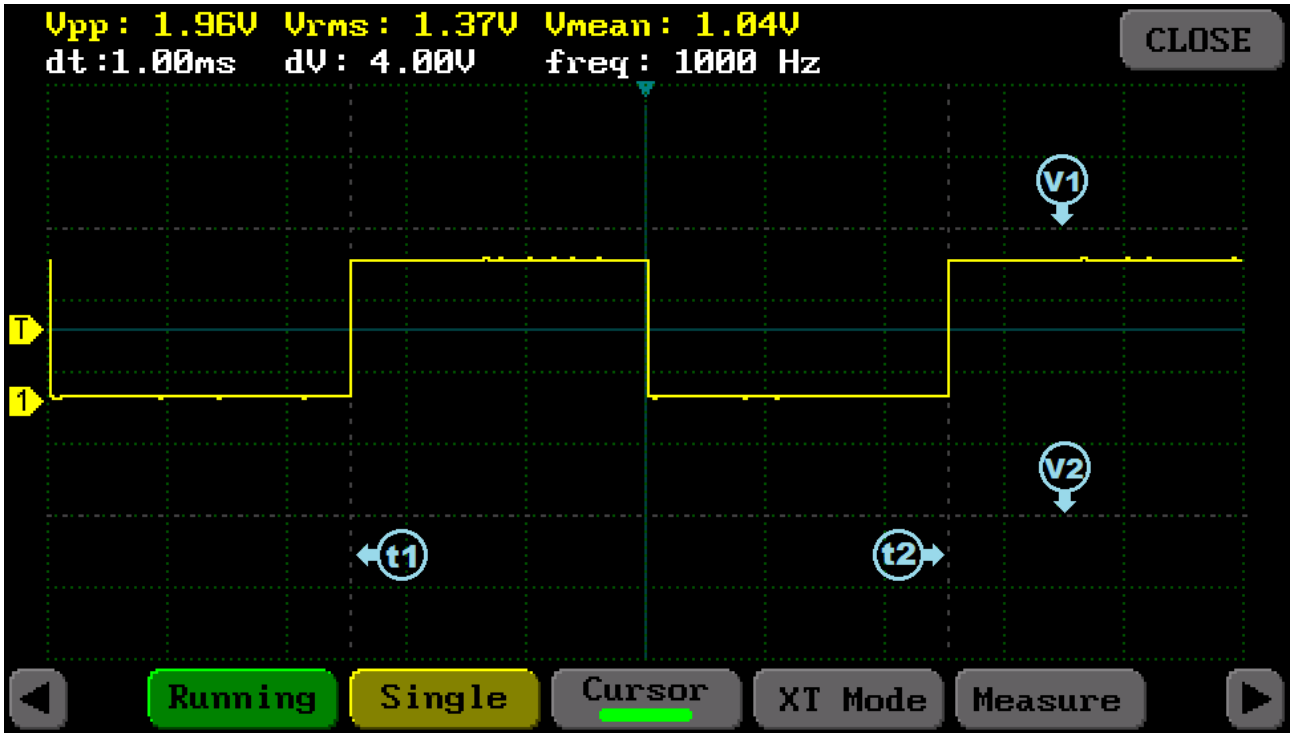

Figure 7. Cursor function

3.6. Auto Measurement

Some values related on signal are measured automatically. The measured values are gathered into two categories; voltage and time. These values are seen in the area (1). In the Menu 2, the 'Measure' menu, which is accessible by selecting the button (24), can be used to select various combinations. These options are shown in the Table 2.

Table 2. Automatic Measuring Options	
V1 & T1	Channel-1 voltage and time values
V2 & T2	Channel-2 voltage and time values
V1 & T2	Channel-1 voltage, Channel-2 time values
V2 & T1	Channel-2 voltage, Channel-1 time values
V1 & V2	Channel-1 and 2 voltage values
T1 & T2	Channel-1 and 2 time values

- T_{on} : The time gap where the signal is positive. If the vertical trigger level (3) is between the maximum and the minimum values, it is calculated as the time of the remaining part over this level. If it is out of the limit values, then the average of the maximum and minimum level is taken and the duration of the remaining time above this part is measured.
- T_{off} : The inverse of t_{on} time. That is, the time remaining below vertical triggering (15) level. The measurement strategy in T_{on} time is also valid here.
- Freq: Frequency of the signal.
- V_{pp} : Peak-to-peak voltage is the difference between the maximum and the minimum amplitudes of a waveform.
- V_{rms} : The RMS value of the sampled signal. When the signal's period is determined, RMS value can be calculated. In case of an undetermined period, the RMS value can be calculated of the signal that available on the screen.
- V_{mean} : The mean value of the sampled signal. The calculations on the signals with a certain period, are according to period; as for the ones with undetermined period, the average value of the signal on the screen is calculated.

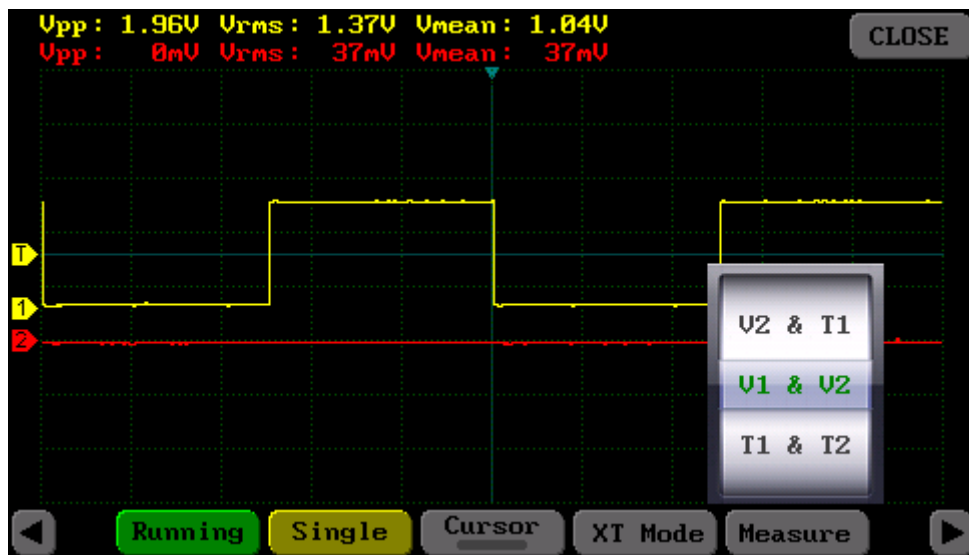

Figure 8. Auto measurement menu

3.7. Operating Mode

The triggering requirement of the oscilloscope defined in the operating mode. These characterizations are performed via the buttons numbered (20) and (21) from the Menu 2 (Figure 3b).

- Running: Determines wave form even if it cannot define triggering requirement in this operating mode. If the triggering does not occur although the oscilloscope waits for a certain time, triggering is initiated necessarily. If it forces occurrence of an invalid trigger, the oscilloscope may not synchronize the wave form and waves are seen as rolling over in the display. In case of a valid triggering, the display remains constant.

- Single: In this operating mode, if it could not define triggering requirement, no signal is seen in display and waits in this way until triggering occurs. After occurrence of the initial triggering saves the signal and reflects in the display and freezes the display.
- Hold: When this button is pressed in any moment, the last signal in the display is frozen.

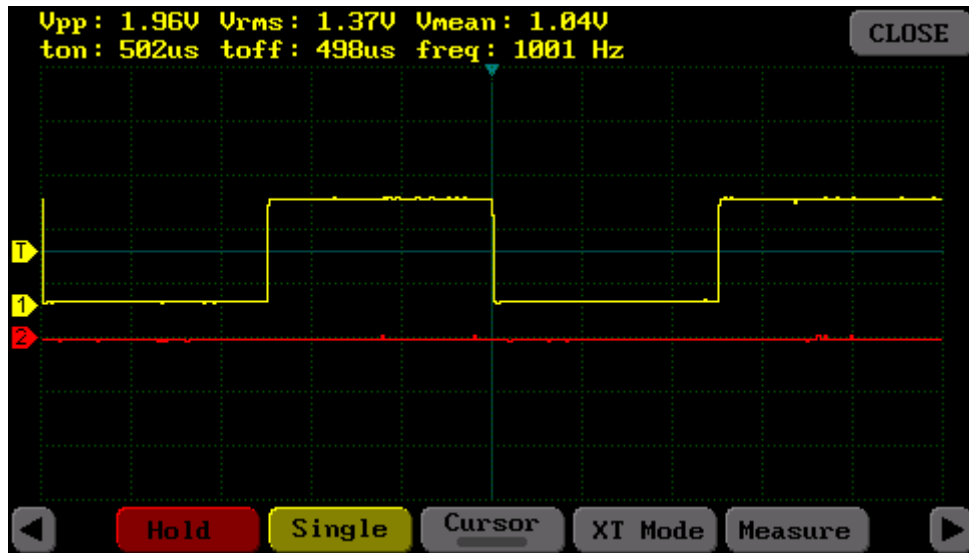

Figure 9. Operating mode (Hold function)

3.8. XY Operating Mode

The XY mode plots one channel against another on the screen. The XY mode is useful to show the phase relationship between periodic signals and for plotting the I-V (current-voltage) character of electronic components.

Electronic components can be characterized by applying a current-limited AC sine wave voltage, and plotting the resulting current flow (I) and voltage drop (V) on the oscilloscope in X-Y display mode.

While, the current flow causes a vertical trace deflection in the display, the voltage causes a horizontal trace deflection. The trace that appears on the display gives an analog signature for the component.

The signature of all analog components is a combination of one or more of the four basic signatures: resistance, capacitance, inductance, and semiconductor. Each of these components reacts differently to the applied AC test signal. For this reason, recognizing the four basic signatures on the oscilloscope display is a key to understanding analog signature analysis.

The signature of a resistance is a line with a slope of 0 to 90 degrees. The capacitance signature is a circle or an ellipse. The diode is a combination of 2 or 3 lines at an angle close to 90 degrees.

Transition to XY mode is provided by selecting (23) numbered button from the Menu 2 (Figure 3b).

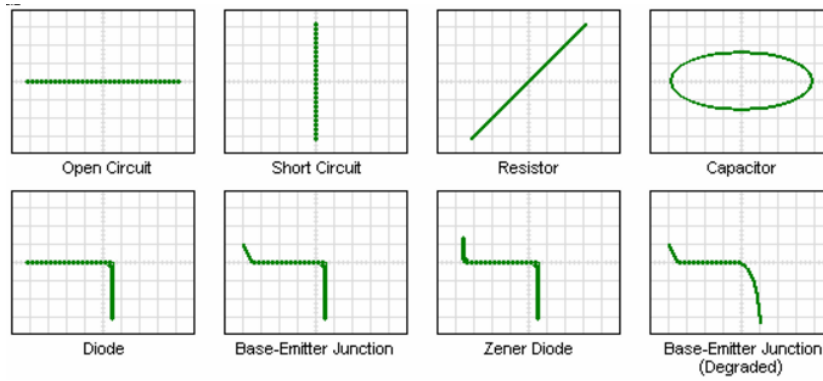

Figure 10. Component characteristics in XY mode (horizontal trace voltage, vertical trace current)

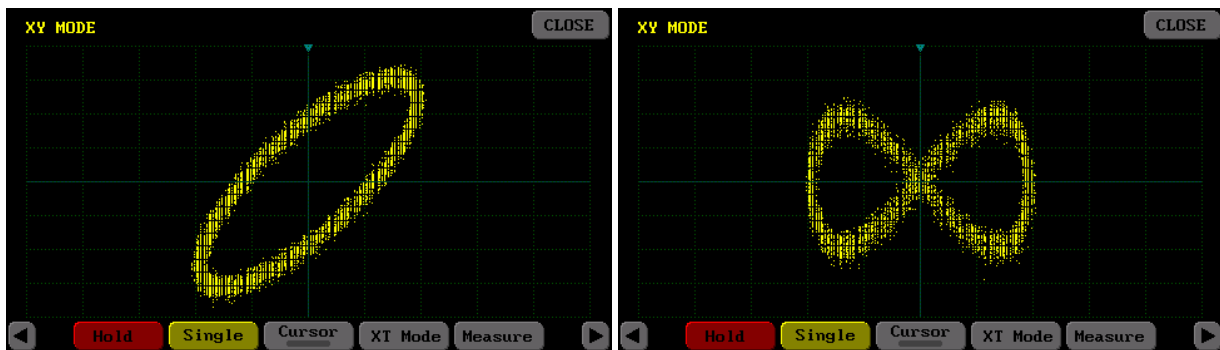

Figure 11. XY mode examples

3.9. Mathematics Function

It is possible to do math calculations among the observed signals via math function. By selecting the button numbered (25), math menu can be accessible (Figure 3c). In the Figure 12, math menu can be seen which has 2 parts. On the left, gain value can be arranged, while the right side is used to select math function. Function and gain information are shown in the area numbered (4).

Table 3. Math Function	
OFF	Turning off the math function
CH1 + CH2	Addition function (Channel 1 + Channel 2)
CH1 - CH2	Subtraction function (Channel 1 – Channel 2)
CH2 - CH1	Subtraction function (Channel 2 – Channel 1)
CH1 * CH2	Multiplication function
CH1 / CH2	Division function (Channel 1 / Channel 2)
CH2 / CH1	Division function (Channel 2 / Channel 1)
CH1 FFT	Fast Fourier Transform for Channel 1
CH2 FFT	Fast Fourier Transform for Channel 2

If the both channels have the same vertical sensitivity value, math operation is made based on voltage. If the vertical sensibilities differ from each other, the operations are made based on pixel value.

To observe the operation result better, it is possible to multiply with a coefficient. Hence, the gain value on the left side of the math menu should be changed (Figure 12). At the Table-4, approximate gain value regarding to the decibel value is shown.

Table 4. Math Function Gain	
40 dB	Gain = 100
34 dB	Gain = 50
26 dB	Gain = 20
20 dB	Gain = 10
14 dB	Gain = 5
6 dB	Gain = 2
0 dB	Gain = 1
-6 dB	Gain = 0.5
-14 dB	Gain = 0.2
-20 dB	Gain = 0.1

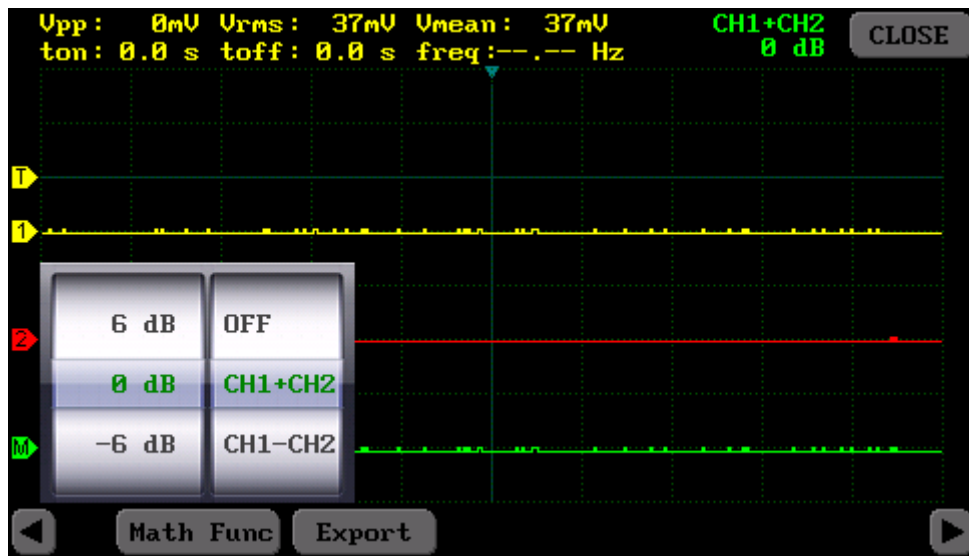

Figure 12. Math function menu

The math channel can be moved vertically on the screen by sweeping upright on the screen. Only in Menu 3 where the math menu is available, the position can be changed.

3.10. Data Logging

The observed data could be saved in two ways;

1. Screen capture: it saves the current screen view as a 16-bit bmp formatted image via the 'Print Sc' button numbered (18).
2. Text formatted record of the data from ADC memory: The values in ADC memory could be recorded as txt formatted text file via the 'Export' button numbered (26) from the Menu 3. The file size may vary depending on the amount of data the ADC has in memory. Text format recording has much more data than picture format and this data can be exported to Excel for detailed analysis.

Note: The internal memory should be formatted to log the data properly (see also Part 7).

4. Signal Generator

64-point data signals are produced by 12-bit 1-Msps DAC on the oscilloscope. In the main menu, when users select 'Signal Generator' (Figure 1) button, the menu below displays (Figure 13). In the menu, there are sliders to arrange the signal's offset voltage, amplitude and frequency. These sliders provide coarse adjustments. Fine adjustments could be done via arrowed buttons on the side. When the tuning is completed, signal generation starts by selecting the 'START' button. Signal output's voltage range is between 0V-4V and output frequency is between almost 1Hz - 50kHz. Signal generator's impedance is 50 Ω. Frequency resolution decreases if the frequency value increases (Table 5).

1Hz	<1000Hz
57Hz	10kHz
228Hz	20kHz
514Hz	30kHz
929Hz	40kHz
1395Hz	50kHz

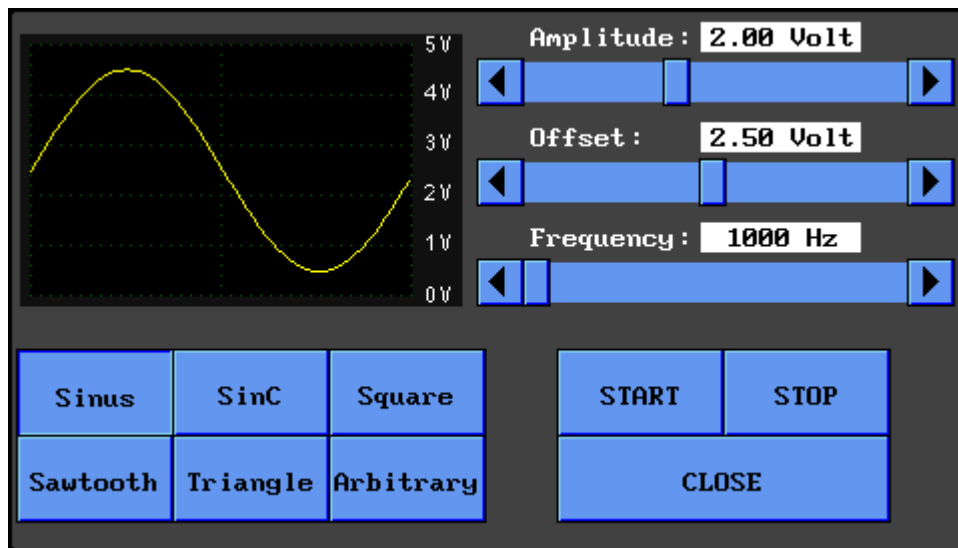

Figure 13. Signal generator

On the left-bottom of the display is a list of signal types that can be generated. In addition to the production of some basic signals (sinus, square, triangle, saw), a special signal, SinC function, may also be produced. In the arbitrary mode, it is also possible to produce special waveforms drawn on the graph with pen.

This drawn waveform is kept in memory so that the device can be used again in the next boot. The signal must be generated by pressing the 'START' button to store the signal data in the memory. If the drawing is canceled by pressing the 'CLOSE' button, it will not be stored in the memory.

5. Color Setting

The optimum color combination was chosen for the oscilloscope design. But it is also possible to personalize these colors. When the 'Set Colors' button on the Settings menu is clicked, we see the following display (Figure 22). In order to change predefined colors on the left side of display click on it. The new color is determined by clicking on the color scale on the right side. Once the color personalization is completed, click 'Save & Exit' button to save the colors and exit. If you want to restore the color combination to its original state, click the 'Default' button and click the 'Save & Exit' button to save.

There are **800** different colors on the color scale.

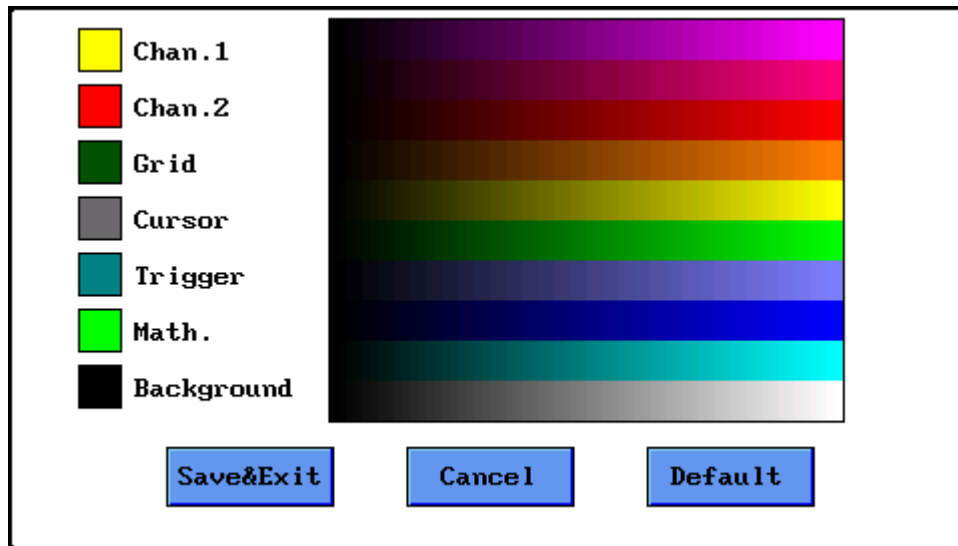

Figure 14. Color setting

6. USB Disk

When the 'USB Disc' button from the main menu is selected, oscilloscope connects to computer as a USB disc. In computer's 'Devices and drivers' section, device is listed (Figure 16). The internal memory access would be available via USB Disc. Thus, the saved files can be transferred to PC platform. To end up the USB Disc connection and switch backward to the main menu, the 'DISCONNECT' button on the screen should be selected.

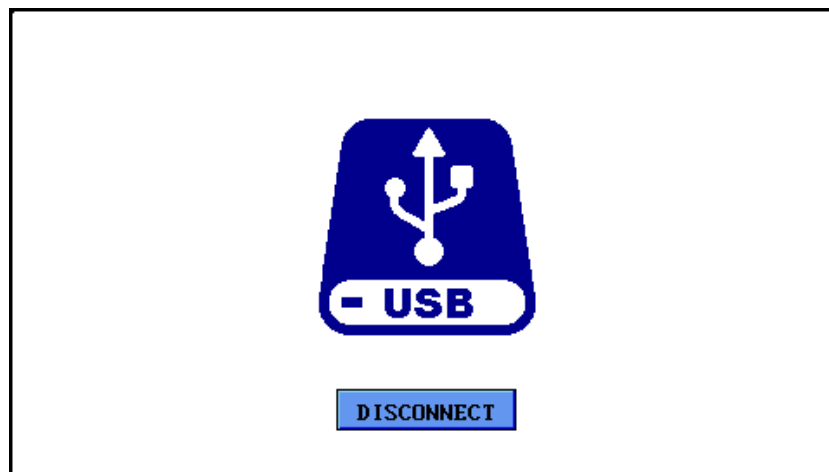

Figure 15. USB Disk LCD screen overview

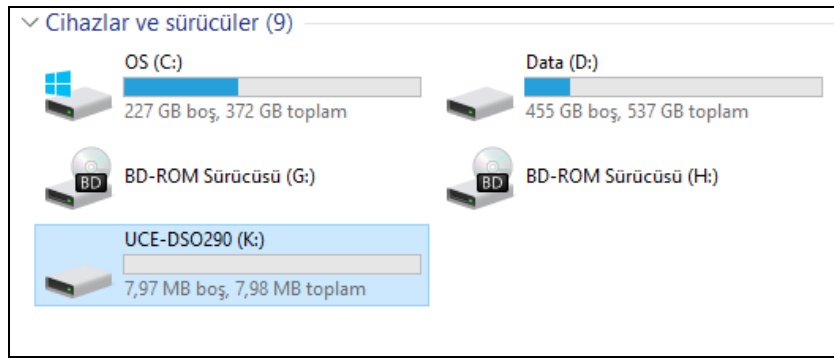

Figure 16. Devices and drivers

7. File Browse

The file browse menu is a menu where screen images recorded in the internal memory can be viewed again. In the main menu, by selecting 'Browse Files' button, users gain access to this menu (Figure 17). On the left side of the screen, there are a list of saved screen captures. The file to be processed would be selected by clicking its name from the list. If user would like to view the file, 'OPEN' button should be clicked. If user would like to delete the file, 'DELETE' button should be clicked. To delete the whole files or format the internal memory; 'FORMAT' button should be clicked, but to complete format, user should click the 'FORMAT' button one more time. To return to the main menu, the 'CLOSE' button should be clicked.

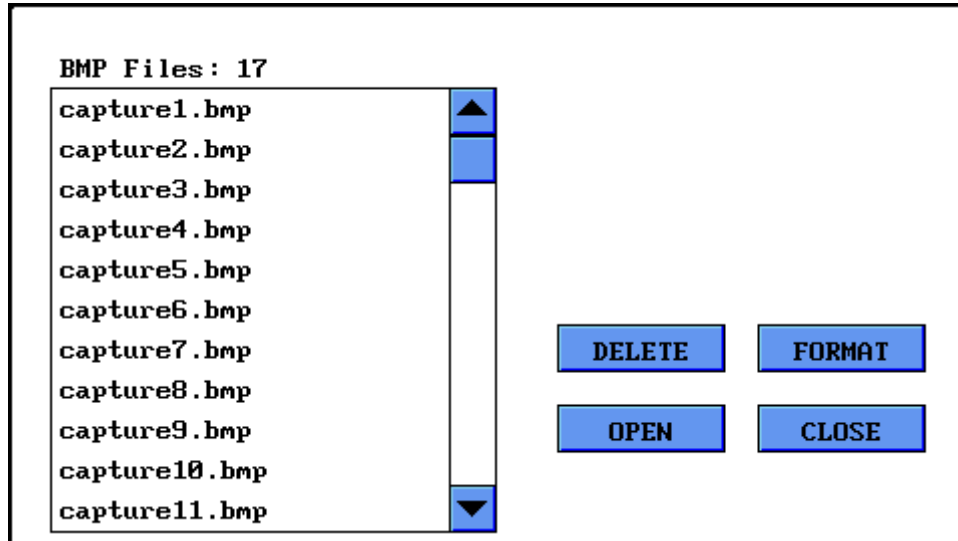

Figure 17. Browse file menu

8. Screen Calibration

When a more precise touch is needed, you may do touch panel calibration. To do this click 'Screen Calibration' and pass to the following display. Press in the middle of crosshair icon on the display with the pen. After four points, if the calibration is successful, the 'smiley face' symbol appears on the display and the program returns to settings menu. If the calibration is unsuccessful, the program prompts you to go back and repeat calibration.

Tip: Use medium touches instead of soft ones during calibration.

Note: After updating software, screen calibration is required again. Right after the updating, in the first start-up, the screen calibration menu appears automatically.



Figure 18. Screen Calibration

9. ADC Calibration

For a better signal sampling, a correct ADC calibration is necessary. Calibration process starts by selecting the 'ADC Calibration' button from the main menu. Probes connected to both channels are connected to GND terminal (Figure 21). If the calibration parameters are stable within the specified limits touch anywhere on the display to complete the calibration and return to settings menu.

Note: After the software update, ADC calibration is required again. Right after the updating, in the first start-up, ADC calibration menu appears automatically.

```
ADC Calibration

1- Connect the probes to Ground before calibration
2- A & B values should be within 120 ~ 140
3- Touch the Screen to calibrate

A:    123
B:    126
CalA:  3
CalB:  0
```

Figure 19. ADC calibration